

## Wentylatory promieniowe

# CMK



### Konstrukcja

Średniociśnieniowy wentylator promieniowy o napędzie bezpośrednim. Wzmocniona obudowa spawana z blachy stalowej. Wirnik o łopatkach pochylonych do tyłu, spawany z blachy stalowej i wyważony dynamicznie.

### Silnik elektryczny

Asynchroniczny jednofazowy 230V, 50Hz lub trójfazowy 400V, 50Hz. Przystosowany do regulacji przetwornicą częstotliwości. Stopień ochrony IP 55, klasa izolacji F.

### Akcesoria



#### HRX

Regulator obrotów  
str. 92

### Zastosowanie

Wirnik o łopatkach pochylonych do tyłu pozwala na transport powietrza zawierającego niewielkie ilości zanieczyszczeń w postaci kurzu, wiórów drewnianych, elementów tekstylnych lub ceramicznych. Doskonale sprawdzają się w instalacjach transportu pneumatycznego.

### Temperatura pracy

Wentylator jest przystosowany do przetwarzania powietrza o temperaturze nie przekraczającej 100°C.

### Dane techniczne

Typ	Wydajność [m <sup>3</sup> /h]	Obroty [rpm]	Moc [kW]	Natężenie [A]	Napięcie [V]	Częstotliwość [Hz]	Ciśnienie [Pa]	Masa [kg]
CMK-250/900 M / CMK-250/900 T	1000	2750	0,37	1,61/0,93	230/400	50	900	20
CMK-280/1000 M / CMK-280/1000 T	1500	2750	0,55	2,39/1,38	230/400	50	1000	28
CMK-315/1100 M / CMK-315/1100 T	1700	2830	0,75	3,26/1,88	230/400	50	1150	32
CMK-315/1200 M / CMK-315/1200 T	2150	2830	1,1	4,78/2,75	230/400	50	1200	32
CMK-355/1500 M / CMK-355/1500 T	2750	2850	1,5	6,52/3,75	230/400	50	1500	44
CMK-355/1950 M / CMK-355/1950 T	2900	2850	2,2	9,57/5,50	230/400	50	1950	47
CMK-400/2000 M / CMK-400/2000 T	4100	2900	3,0	13,04/7,50	230/400	50	2000	59
- / CMK-400/2200 T	4800	2900	4,0	-/10,00	400	50	2200	60
- / CMK-450/2400 T	5100	2900	5,5	-/13,75	400	50	2400	80
- / CMK-450/2900 T	6500	2900	7,5	-/18,75	400	50	2900	81
- / CMK-500/3300 T	7400	2900	7,5	-/18,75	400	50	3300	102
- / CMK-500/3700 T	8600	2930	11,0	-/27,50	400	50	3700	120
- / CMK-560/3750 T	11000	2930	15,0	-/37,50	400	50	3750	140
- / CMK-560/4300 T	13200	2930	17,5	-/43,75	400	50	4300	145

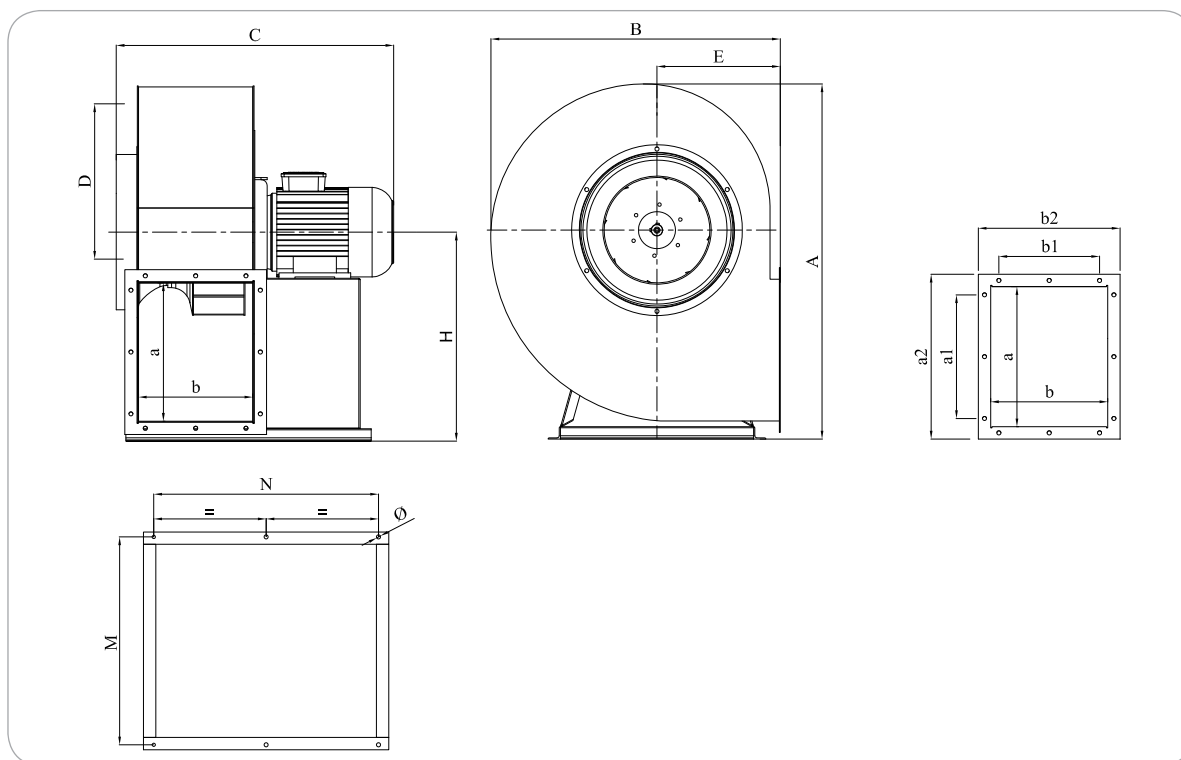

## Wymiary [mm]

Typ	A	B	C	D	E	H	H1	M	N	a	b	a1	b1	a2	b2	Ø
<b>CMK-250/900</b>	564	440	465	235	182	351	301	310	403	214	172	174	120	274	232	10
<b>CMK-280/1000</b>	614	493	485	260	203	376	330	356	423	240	212	200	160	300	272	10
<b>CMK-315/1100</b>	680	554	541	320	239	412	352	412	450	272	230	232	190	332	290	10
<b>CMK-315/1200</b>	680	554	541	320	239	412	352	412	450	272	230	232	190	332	290	10
<b>CMK-355/1500</b>	773	625	575	325	275	463	398	456	482	307	260	266	220	367	320	10
<b>CMK-355/1950</b>	773	625	575	325	275	463	398	456	482	307	260	266	220	367	320	10
<b>CMK-400/2000</b>	865	704	658	375	300	508	453	506	547	341	285	301	245	401	345	10
<b>CMK-400/2200</b>	865	704	674	375	300	508	453	506	547	341	285	301	245	401	345	10
<b>CMK-450/2400</b>	976	791	756	414	337	575	505	586	620	384	310	344	270	444	370	10
<b>CMK-450/2900</b>	976	791	756	414	337	575	505	586	620	384	350	381	310	481	410	10
<b>CMK-500/3300</b>	1083	850	796	454	355	635	545	636	701	421	350	381	310	481	410	10
<b>CMK-500/3700</b>	1083	850	912	454	355	635	545	636	811	421	350	381	310	481	410	10
<b>CMK-560/3750</b>	1196	955	952	497	400	693	600	726	852	472	390	432	350	532	450	10
<b>CMK-560/4300</b>	1196	955	952	497	400	693	600	726	852	472	390	432	350	532	450	10

